

SHIPPING BILL				BILL OF MATERIAL			
QTY	MARK	MARK	QTY	DESCRIPTION	LENGTH	WEIGHT	REMARKS
1	1212S1			STAIRS		843	
		1212S1	1	MC12X10.6	14'-5"	152	A36
		a1026	1	L3X3X3/8	4'-0"	29	A36
		m1007	1	MC12X10.6	14'-5"	152	A36
		m1026	12	SHT12GAX22 1/16"	4'-0"	448	A36 12 GA PAN
		m1031	1	SHT12GAX24 1/2"	4'-0"	42	A36 12 GA PAN
		m1034	1	SHT12GAX3 3/8"	4'-0"	6	A36 12 GA PAN
		m1079	1	MC12X10.6	0'-5 9/16"	5	A36
		m1080	1	MC12X10.6	0'-5 9/16"	5	A36
		p1012	2	PL1/4"X1 1/2"	0'-5"	1	A36
		p1016	1	PL1/4"X1 1/2"	0'-2 11/16"	0	A36
		p1017	1	PL1/4"X1 1/2"	1'-0 11/16"	1	A36
		p1086	1	PL1/4"X1 1/2"	0'-2 11/16"	0	A36
		p1088	1	PL1/4"X1 1/2"	1'-0 5/8"	1	A36
TOTAL WEIGHT THIS DRAWING						843	

Member	TOTAL QTY.	FIELD BOLTS	LENGTH

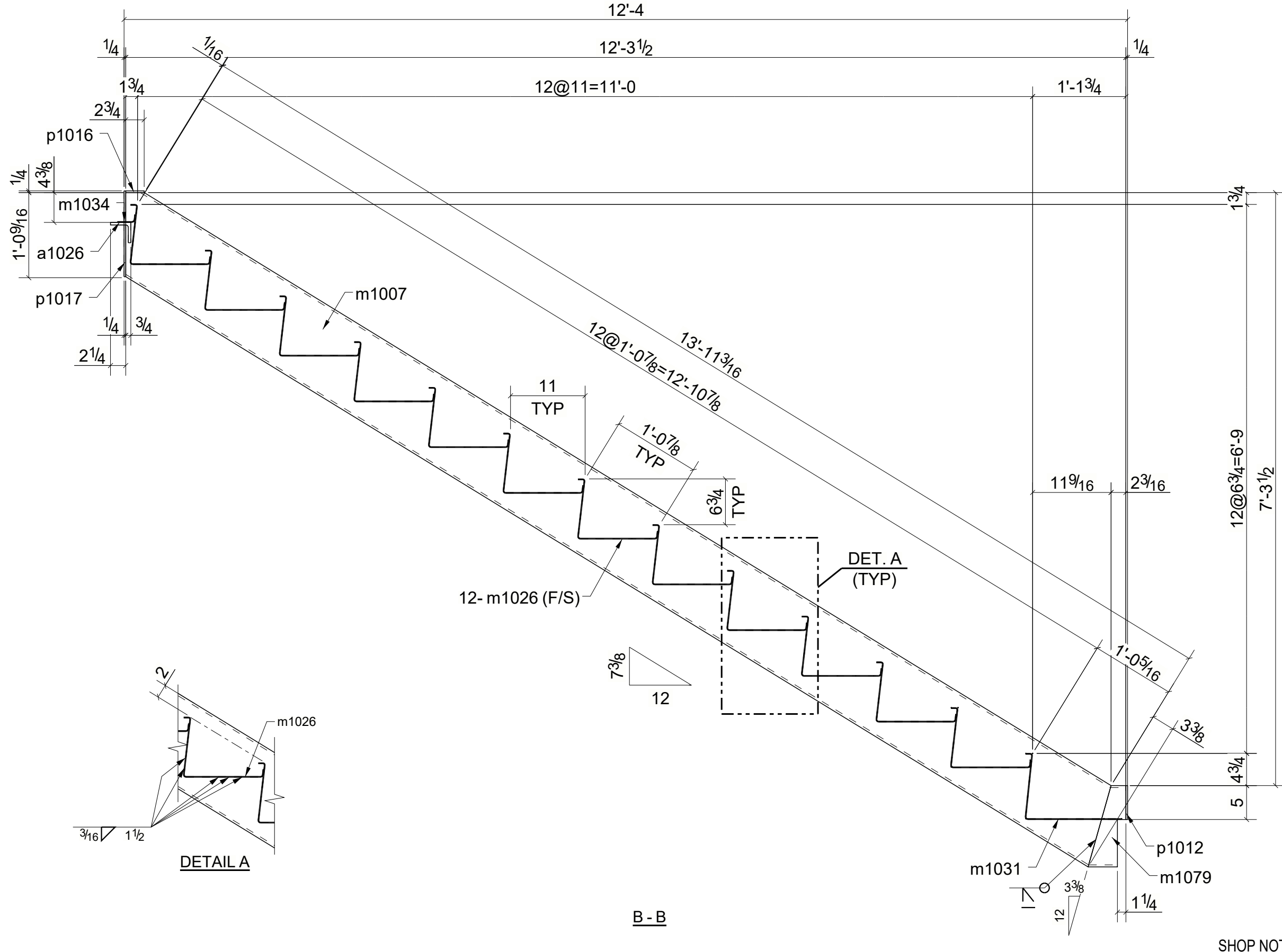
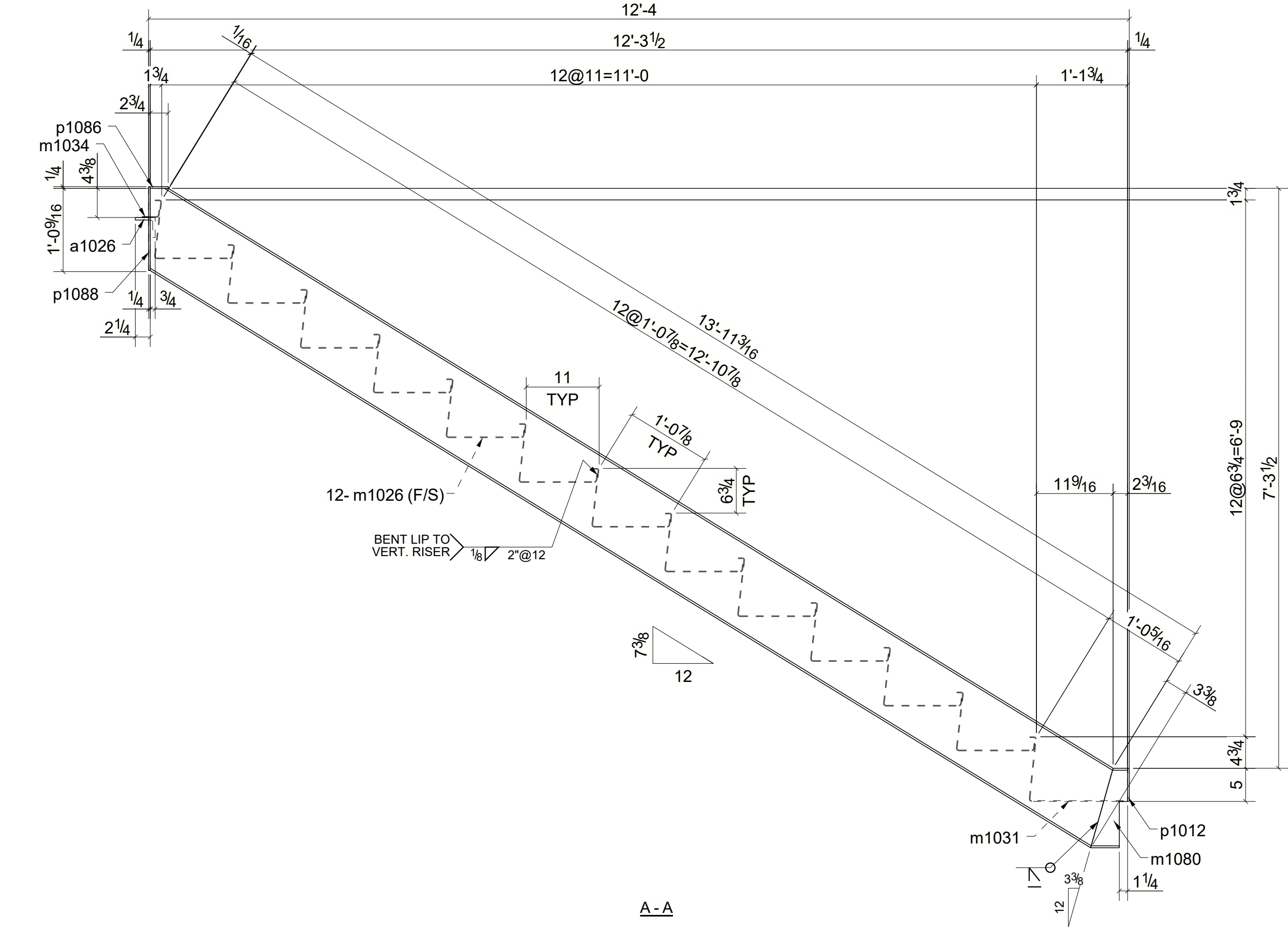
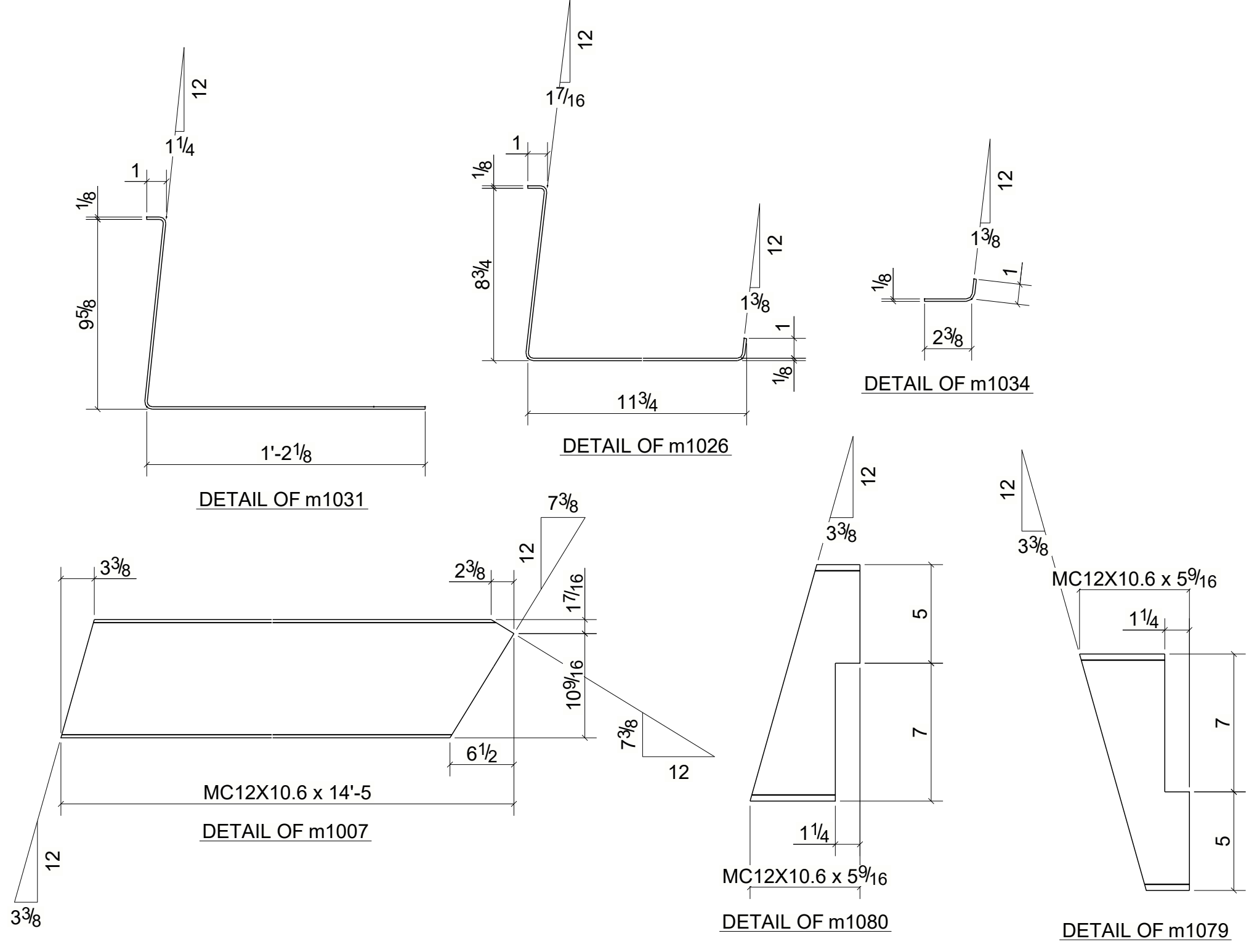
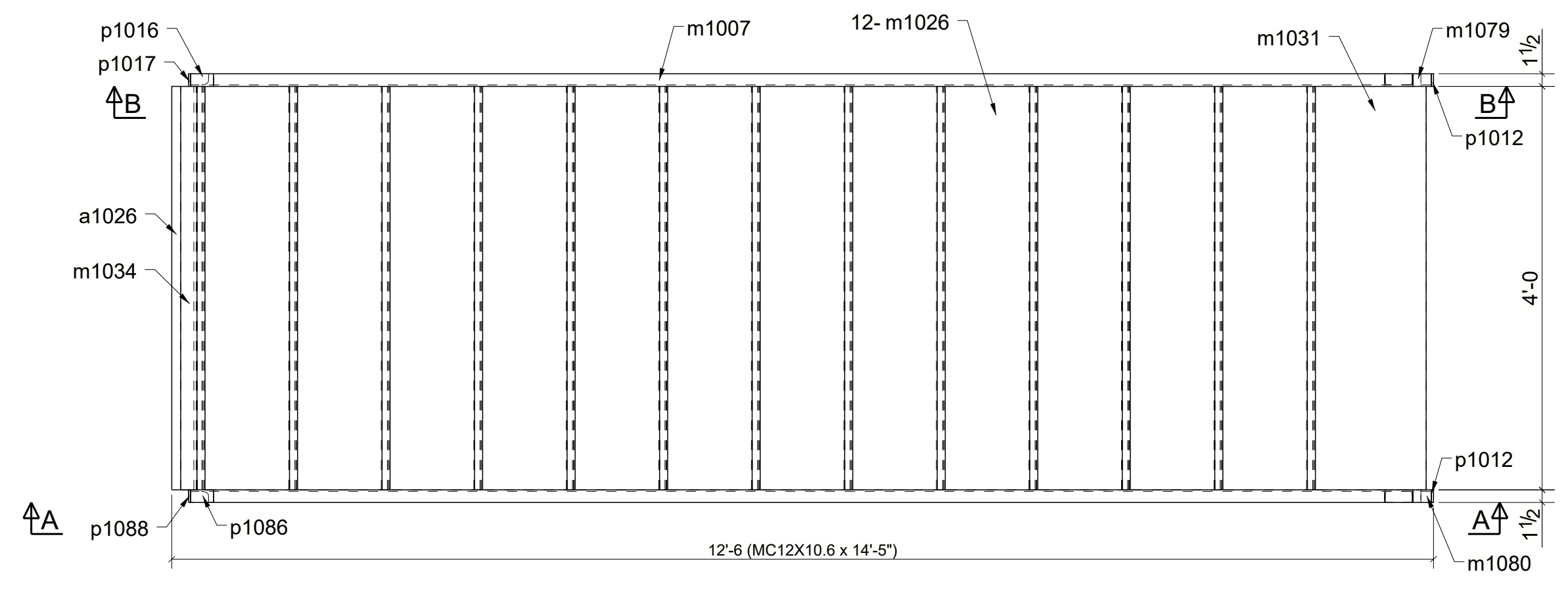

ONE - STAIR - 1212S1

For Fabrication

SHOP NOTES:
 1. ALL STEELS ARE A36 U.N.O.
 2. Ⓢ - DENOTES CONNECTING SIDE MARK.
 PAINT : CENTURY COATING 220-D-344 GRAY PRIMER HOLES : 13/16" UNL. NTD.
 SURFACE PREP : MIL THICKNESS ELECTRODES : E70XX UNL. NTD.

REVISIONS		
NO.	DATE	BY
0	02/18/2021	PBH

NOTICE TO CONTRACTORS AND ERECTOR
 BACK CHARGES FOR CORRECTIVE WORK OR REPLACED MATERIALS WILL NOT BE ACCEPTED UNLESS AUTHORIZED IN WRITING BY POSTEL INTERNATIONAL INC. BEFORE SUCH COSTS ARE INCURRED

DRAWN BY: VRK CHKD BY: PBH JOB NO. SHEET NO. 1212
 DATE: 02/08/2021 DATE: 02/08/2021

